

INSTRUCTION MANUAL FOR PORTABLE BASKETBALL STAND

Fix the pad DD on braces U3, U4 by velcro as shown.

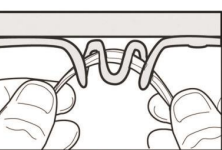

Fix the net P on ring AA

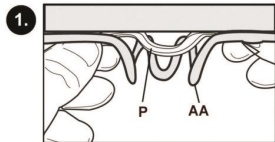
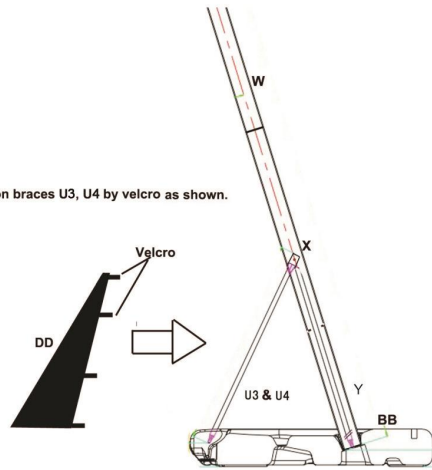
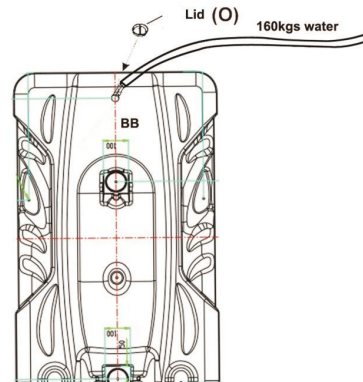

Filling the base with water or sand



Notice to assemblers:

All the basketball systems, including those used for displays, must be assembled and ballasted according to instructions. Failure to follow instructions could result in serious injury. Please read all warnings and cautions before assembly. It is recommended to supervise children as they play with this product. This product is to be assembled by 4 adults only!

We appreciate your purchasing one of our many fine products. We are assure that you will be very satisfied with your selection.



SAFETY INSTRUCTIONS



Owner must ensure that all players know and follow these rules for safe operation of the system.

To ensure safety, do not attempt to assemble this system without following the instructions carefully. Check entire box and inside all packing material for parts and/or additional instruction material. Before beginning assembly, read the instructions and identify parts using the hardware identifier and parts list in this document. Proper and complete assembly, use, and supervision are essential for proper operation and to reduce the risk of accident or injury. A high probability of serious injury exists if this system is not installed, maintained, and operated properly.

- If using a ladder during assembly, use extreme caution.
- Four(4) capable adults are recommended for this operation.
- Check base regularly for leakage. Slow leaks could cause system to tip over unexpectedly.
- Seat the pole sections properly (if applicable). Failure to do so could allow the pole sections to separate during play and/or transport of the system.
- Climate, corrosion, or misuse could result in system failure.
- Minimum operational height is 6' 6" (1.98 m) to the bottom of backboard.
- This equipment is intended for home recreational use only and NOT excessive competitive play.
- Read and understand the warning label affixed to pole.
- The life of your basketball pole depends on many conditions. The climate, placement of the pole, location of the pole, exposure to corrosives such as pesticides, herbicides, or salts are all important.
- Adult supervision is recommended when adjusting height.

WARNING

Read and understand warnings listed below before using this product.

Failure to follow these warnings may result in serious injury and/or property damage.

Owner must ensure that all players know and follow these rules for safe operation of the system.

- DO NOT HANG on the rim or any part of the system including backboard, support braces or net.
- During play, especially when performing dunk type activities, keep player's face away from the backboard, rim and net.
- Do not slide, climb, shake or play on base and/or pole.
- After assembly is complete, fill system completely with water or sand. Never leave system in an upright position without filling base with weight, as system may tip over causing injuries.
- When adjusting height or moving system, keep hands and fingers away from moving parts.
- Do not allow children to move or adjust system.
- During play, do not wear jewelry (rings, watches, necklaces, etc.). Objects may entangle in net.
- Surface beneath the base must be smooth and free of gravel or other sharp objects. Punctures cause leakage and could cause system to tip over.
- Keep organic material away from pole base. Grass, litter, etc. could cause corrosion and/or deterioration.
- Check pole system for signs of corrosion (rust, pitting, chipping) and repaint with exterior enamel paint. If rust has penetrated through the steel anywhere, replace pole immediately.
- Check system before each use for proper ballast, loose hardware, excessive wear and signs of corrosion and repair before use.
- Check system before each use for instability.
- Do not use system during windy and/or severe weather conditions; system may tip over. Place system in the storage position and/or in an area protected from the wind and free from personal property and/or overhead wires.
- Never play on damaged equipment.
- When moving system, use caution to keep mechanism from shifting.
- Keep pole top covered with cap at all times.
- Do not allow water in tank to freeze. During sub-freezing weather add 2 gallons of non-toxic antifreeze, sand or empty tank completely and store. (Do not use salt.)
- While moving system, do not allow anyone to stand or sit on base or have added ballasting on base.
- Do not leave system unsupervised or play on system when wheels are engaged for moving.
- Use Caution when moving system across uneven surfaces. System may tip over.
- Use extreme caution if placing system on sloped surface. System may tip over more easily.
- See instruction manual for proper installation and maintenance.

HEIGHT ADJUSTMENT

Backboard and rim height adjustment is from 7-1/2' to 10'.

Rotate crank handle to raise and lower backboard

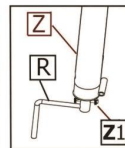

Handle (R) can be removed or stored by removing small

bolt (Z1) at the end of adjustment mechanism (Z)

MOVING SYSTEM

1. Adjust basketball backboard height to lowest position.
2. While holding pole, rotate basketball system forward until wheels engage with ground.
3. Move basketball system to desired location.
4. Carefully rotate basketball system upright.
5. Check system for stability.



Install backboard brace S, T on the top pole W

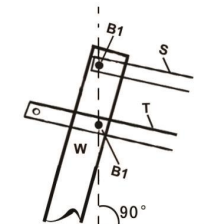
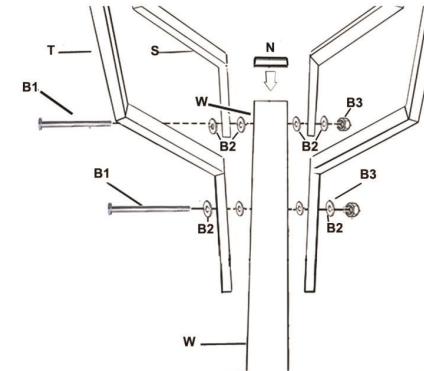

Ground

Install adjustment mechanism Z as shown.

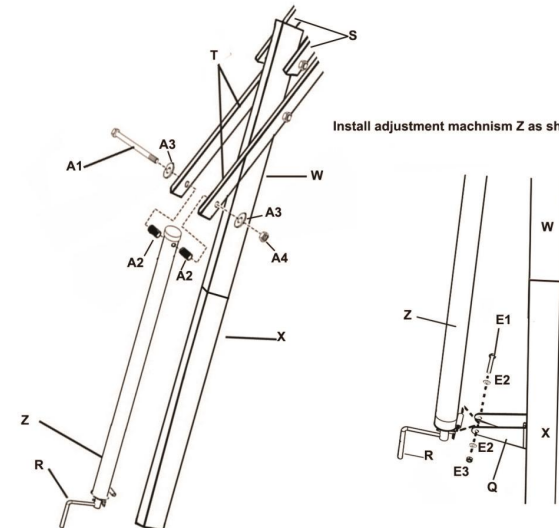

Assemble ring AA on the front of backboard CC as shown. Please note that you must take apart the springs inside ring case before assemble the ring AA.

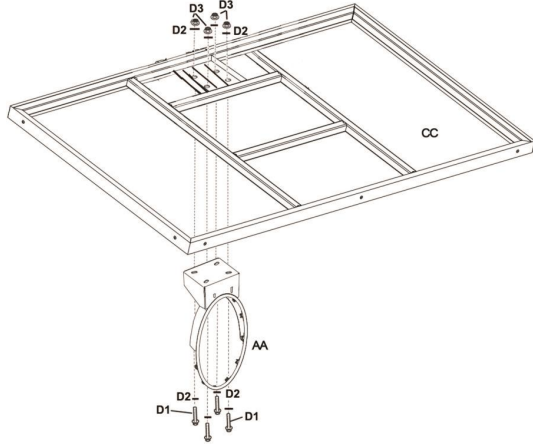

Install the backboard brace S, T on the back of backboard CC as shown.

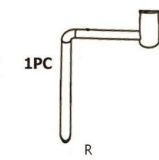
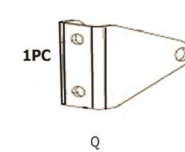
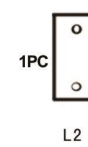
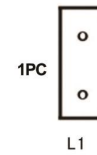
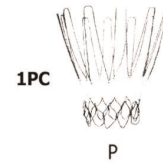
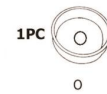
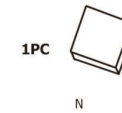
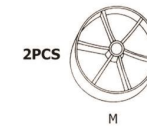
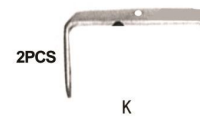
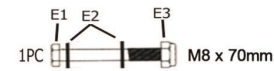
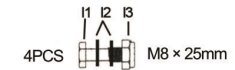
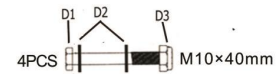
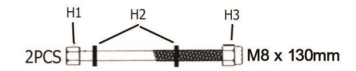
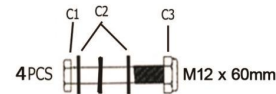
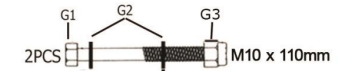
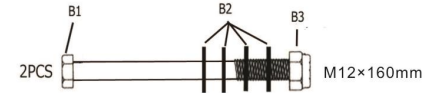
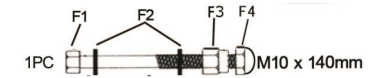
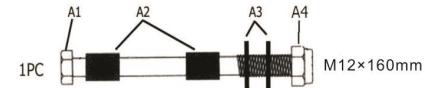
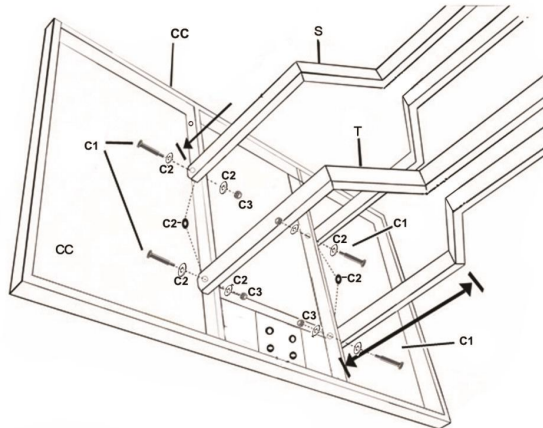

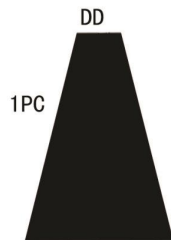
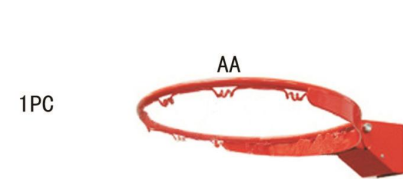
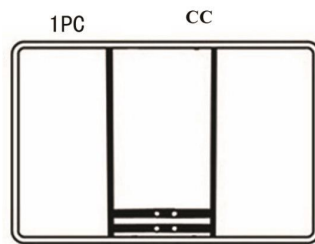
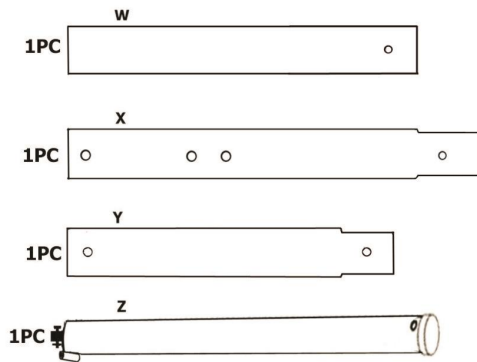
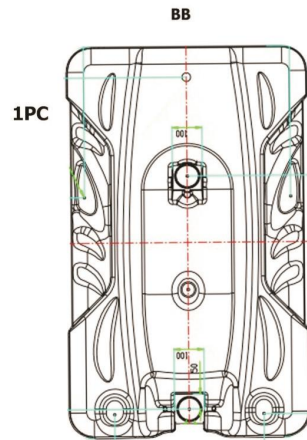
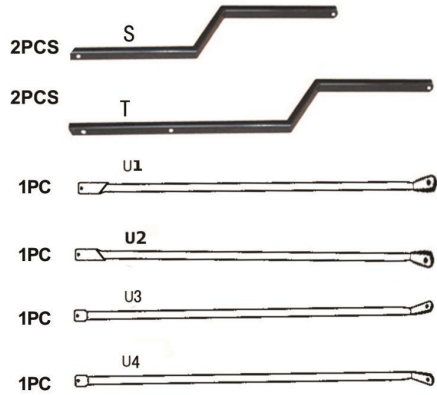

Install 3pcs main poles W, X, Y together as shown

Strike the bottom of the pole firmly several tie on a piece of acrap wood

Fix bracket Q, Plate L1 & L2 on the middle pole X by bolts set H1, H2, H3

Fix the 3 piece main poles by bolt set G1, G2, G3

Fix the bottom pole Y on base BB by bolt J1. Make sure bracket Q face the back for next assemble step.

1. Fix top end of the 4pcs braces U1, U2, U3, U4 on middle pole X by bolts set F1, F2, F3, F4, please note that the top end of braces U1 & U2 must lean on the middle pole X, inside of braces U3 & U4.

2. Insert the wheel axle V into wheel M, wheel bracket K and base BB as above picture.

3. According to the right picture, fix bottom end of braces U1 & U2 on the two sides of base BB, and fix the bottom end of braces U3 & U4 on the front of base BB by bolts set I1, I2, I3, I4. Please make sure the bottom end of braces U3 & U4 must be fixed on wheel bracket K together.